



Leading Humidification Innovation... Once Again

# Nortec's GS Series Condensing High Efficiency



# We Love Humidity

Productivity and quality of life are directly affected by the indoor environment. People work better in favorable surroundings. So do your products and your equipment! They all respond in various ways to changes in air quality, temperature and humidity. All three elements must be just right to maximize performance and reliability, both with humans and equipment. Correct humidification is critical, since too much humidity can be as destructive as too little.

Nortec is a world leader in state of the art humidification technology. Our focus is concentrated exclusively on designing and building better humidification systems. Every Nortec GS Series model has been engineered to meet the highest standards of cost effective, efficient performance. They are designed for ease of installation, adaptability, simplicity of operation,

ease of maintenance and servicing, energy efficiency cleanliness and long term reliability.

Nortec GS Series humidifiers offer complete application flexibility to system engineers, contractors and customers.

You can count on Nortec when you need humidity for:

- commercial offices
- schools and libraries
- museums and art galleries
- manufacturing facilities
- laboratories
- hospitals
- printing plants

## The New GS Series

### Pushing the boundaries of high efficiency operation

Nortec has been manufacturing Gas-Fired humidification systems for almost two decades now and we're still looking to improve on our past designs. Our future stands on our ability to understand the needs of all our customers and to create appropriate solutions. Our newest GS Series keeps all of our long standing objectives in mind, showcased in our most efficient package yet.

### Easy cleaning and maintenance

Humidifier maintenance has been simplified with a new tank and heat exchanger design. Less consumables reduces maintenance time as well as cost.

### More standard features

More standard features means more flexibility. The GS comes fully stocked as a complete out of the box system.

Seamless integration into existing Building Management Systems

Standard connection using Modbus, BACnet IP and BACnet MSTP (slave). Option required for LonWorks and BTL certified BACnet available.



## Application Flexibility



Compact Size Unit

**GS-50**

**GS-100**

- Smaller footprint
- Fits through 36" door
- Reduced clearances



Full Size Unit

**GS-150**

**GS-200**

**GS-300**

**GS-450**

**GS-600**

# CS<sub>NX</sub>

Available Models  
Condensing System • Low NOx Emissions



GS-600

*we love humidity*

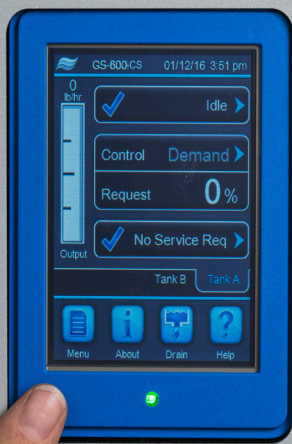

## Economic Operation

# Condensing system payback in less than 3 seasons

Nortec GS Series gas-fired humidifiers provide clean steam humidification at an economical operating cost. Units are packaged in a powder coated cabinet for zero clearance space requirement while offering high efficiency output. They can be controlled from either a local humidistat or from the central Building Management System.

The combustion system uses a modulating forced draft combustion air blower, a negative pressure regulator gas valve and a 100% premix burner. On a call for humidity, the combustion air blower starts creating a negative pressure across the valve orifice located at the air inlet. The gas valve opens and the regulated gas/air mixture is forced through the burner ports and is ignited by the spark igniter. Integrated flame and air flow sensors ensure safe operation.

**Humidifier  
Annual Operating Cost  
Natural Gas vs. Electric**  
100 lbs/hr (45 kg/hr)

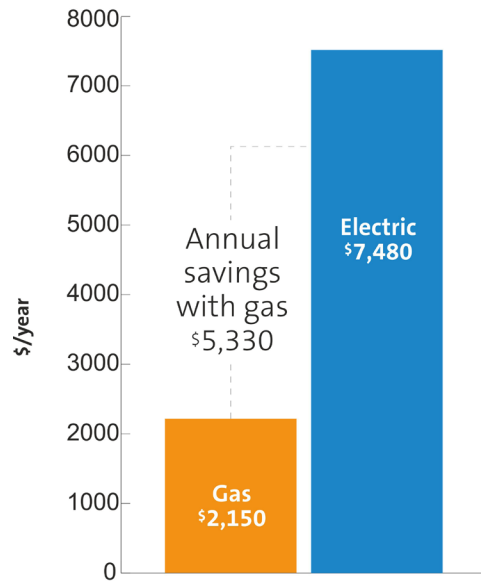

Operating costs based on an electric cost of \$0.11 per kWh, natural gas cost \$0.90 per therm, full output for 2,000 hours per season. Efficiency of electric product is 100% and efficiency of gas unit is 91%. Costs do not include Electric Peak demand charges.



Installation Savings

## CPVC Venting

A new venting option that is being introduced with the Condensing System (CS) and Low NOx Emissions (NX) units is CPVC venting.

This is a great alternative to stainless steel venting. Not only is it easier to work with, but installation costs are greatly reduced creating short pay back periods.

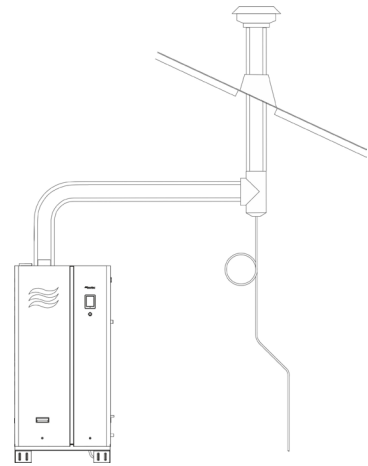

## Model Specifications

	Condensing Systems (CS)	Low NOx Emissions (NX)
Efficiency	up to 94%	up to 87%
Exhaust Temperature	140°F / 60°C	140°F / 60°C
Venting	CPVC, BH	CPVC, BH

*we love humidity*

# No Sweat Maintenance

The new GS is designed with many features to help keep scaling to a minimum as well as facilitate maintenance.

## **New Heat Exchanger Design**

Smooth, well spaced mandrel design for easy cleaning.

## **Automatic Blow Downs**

Programmable automatic tank blow down breaks up scale and refreshes water in the unit, reducing scale build up.

## **Largest Possible Cleanout Port**

No lips and the largest possible view of the tank allow for simplified and more efficient maintenance.

## **Sharp Corner Reduction**

The new tank design has been rounded out to make the corners more accessible to clean out scale deposits.

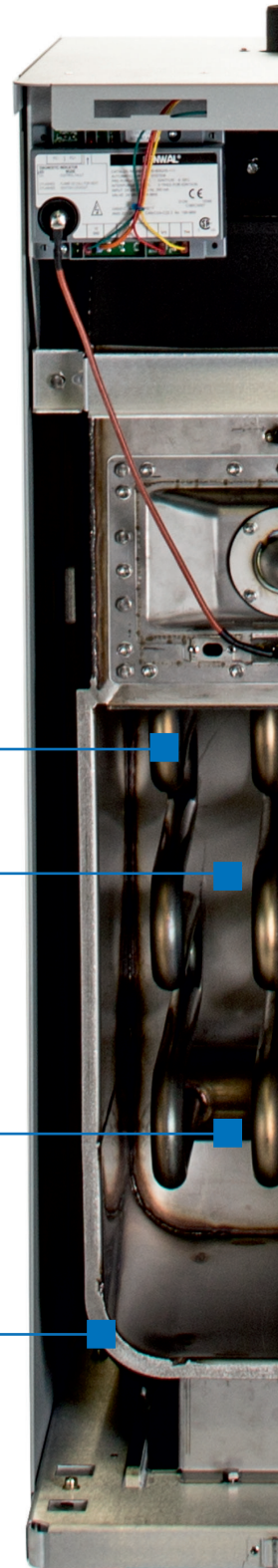

# Reliable Design

Our Gas-Fired humidification systems continue to be made with dependable components for maximum reliable operation.

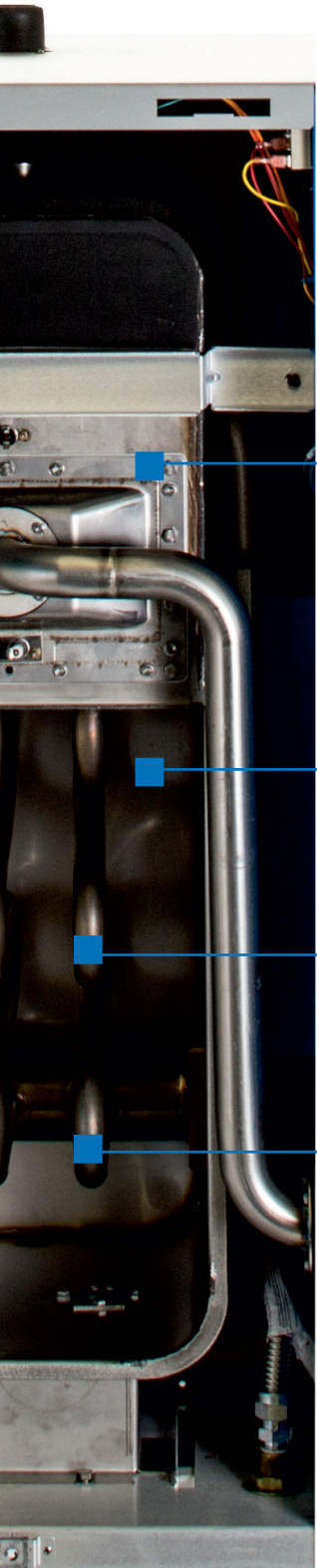

## **304 S.S Rounded Tank**

Thick gauge stainless steel tank with reduced welds makes for a stronger design

## **Sacrificial Anode**

A replaceable sacrificial anode is located in the tank on the door, reducing corrosion to the tank and increasing humidifier life cycle.

## **316 S.S. Heat Exchanger**

Stainless steel, heat treated heat exchanger

## **Mandrel Style Heat Exchanger**

New mandrel bent tube design reduces welds and makes for easy scale maintenance

*we love humidity*

## Features and Accessories

	Feature	Accessory
Stainless steel tank and heat exchanger	■	
Continuous self-diagnostic with self-correction	■	
Fail safe operation	■	
Zero clearance to combustibles	■	
Intuitive scale management based on steam production	■	
Precise float water level management system	■	
Smart drain water cooling	■	
Manual auxiliary drain	■	
Keep warm feature	■	
Full tank blowdown capability via timer or external trigger	■	
BH / Special gas vent or CPVC venting options	■	
Potable, DI and RO water	■	
Integrated touch screen controller	■	
Modbus communication interface	■	
BACnet IP communication system interface	■	
Link-up system	■	
Real-time clock	■	
On screen troubleshooting	■	
Timer programming	■	
Sealed combustion	■	
External drain water cooler		■
Humidity sensors and humidistats		■
Unit stand		■
In-line water filter		■
Sump pump		■

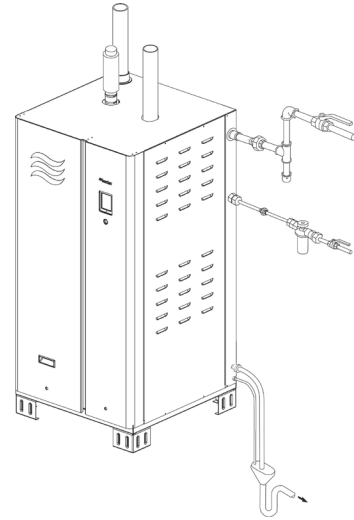

- Natural or propane gas
- BTL certified BACnet
- LonWorks Communication

## Technical Data

Specification	Compact Size Unit		Full Size Unit				
	GS-50	GS-100	GS-150	GS-200	GS-300	GS-450	GS-600
Capacity lbs/hr (kg/hr)	50 (23)	100 (45)	150 (68)	200 (91)	300 (136)	450 (204)	600 (272)
Dimensions (WxHxD) in (cm)	24x44x22 (61x112x56)	24x44x22 (61x112x56)	27x56x28 (69x112x69)	38x56x28 (97x143x71)	38x56x28 (97x143x71)	63x56x28 (160x143x71)	74x56x28 (188x143x71)
Operating Weight lb (kg)	340 (154)	365 (166)	500 (227)	775 (352)	800 (363)	1200 (545)	1550 (703)
Mounting	Stand / Wall		Stand / Floor				
Power Circuit	110/120 V / 1 Phase / 60 Hz						
Models	Condensing System (CS), Low NOx Emissions (NX)						

Nortec is the world's leading manufacturer of commercial and industrial humidification and evaporative cooling products and systems, setting standards with regard to energy efficiency and hygienic solutions.

**USA** 2700 90th Street, Sturtevant, WI 53177  
835 Commerce Park Drive, Ogdensburg, NY 13669  
**Canada** 2740 Fenton Road, Ottawa, Ontario K1T3T7  
**Tel** 1.866.NORTEC1 **Email** nortec@humidity.com

  
humidity.com